



Main Features

- Ranges: from 4 to 1000 bar
- Nominal Output Signal:
0...10Vdc (3 wires) / 4...20mA (2 wires)
0.5...4.5 v ratiometric / 1...5 V (3 wires)
- Compact size
- Wetted parts: Stainless steel
- SIL 2 certified according to EN IEC 62061:2021 and IEC/EN 61508:2010
- PL d certified according to EN ISO 13849-1:2015 and EN ISO 13849-2:2012
- Electromagnetic immunity up to 100 V/m

KM transmitters are based on thick film sensing element deposited on stainless steel diaphragm.

Thanks to the latest state of the art SMD electronics and compact all stainless steel construction, these products are extremely robust and reliable, and are certified SIL2/PL d.

KM transmitters are suitable for all industrial applications, especially on hydraulics (presses, pumps, power pack, fluid power, etc.) with severe conditions usually with high level of shock, vibration, pressure and temperature peaks, as typical for mobile machines environment.



This symbol present on the product label stands for further indications on product manual. For correct and safe installation, follow the instructions and observe the warnings contained in this manual. No hazards shall arise by any reasonably foreseeable misuse in a way not intended, and not described in this manual. The complete manual is available for download from the website www.gefran.com. UL file number E216851

FS = Full scale

- 1) Incl. Non-Linearity, Hysteresis, Repeatability, Zero-offset and Span-offset tolerance (acc. to IEC 62828-2)
- 2) The operating pressure range is intended from 0.5 to 100% FS
- 3) Time within which the rated performance is achieved
- 4) See possible restrictions in the paragraphs "Electrical connections" and "Accessories on request".

TECHNICAL DATA

Non Linearity (BFSL)

± 0.15% FS (typ); ± 0.25% FS (max)

Hysteresis

+ 0.1% FS (typ); + 0.15% FS (max)

Repeatability

± 0.025% FS (typ); ± 0.05% FS (max)

Zero offset tolerance

± 0.15% FS (typ); ± 0.25% FS (max)

Span offset tolerance

± 0.15% FS (typ); ± 0.25% FS (max)

Accuracy at room temperature (1)

< ± 0.5% FS

Pressure ranges (2)

From 4 bar to 1000 bar (See table)

Overvoltage

36 Vdc continuous

48 Vdc according to ISO7637-2 Pulse 5

Insulation voltage

500 Vdc

Overpressure (without degrading performance)

See table

Pressure containment (burst test)

See table

Pressure Media

Fluids compatible with Stainless Steel AISI 430F and 17-4 PH

Housing

Stainless Steel AISI 304

Long term stability (accuracy)

<0,2%FS per year (within compensated temperature range -20...+85 C° and nominal pressure range)

Operating temperature range (process)

-40...+125°C (-40...+257°F)

Operating temperature range (ambient) (4)

-40...+125°C (-40...+257°F)

Compensated temperature range

-20...+85°C (-4...+185°F)

Storage temperature range

-40...+125°C (-40...+257°F)

Temperature effects over compensated range (zero)

± 0.01% FS/°C typ (± 0.02% FS/°C max.)

Temperature effects over compensated range (span)

± 0.01% FS/°C typ (± 0.02% FS/°C max.)

Response time (10...90%FS)

< 1 msec.

Warm-up time (3)

< 30 sec.

Mounting position effects

Negligible

Humidity

Up to 100%RH non-condensing

Weight

50 gr. nominal

Mechanical shock

100g 6ms according to IEC 60068-2-27

50g 11ms according to ISO 19014-3

Vibrations

20g max at 10...2000 Hz according to IEC 60068-2-6

Random ASD 10...2000Hz according to ISO 19014-3

Ingress protection

IP67/IP69K with female homologated connector mounted (not UL evaluated)

Output short circuit and reverse polarity protection

YES

Nominal Output signal (short circuit protected)	4...20 mA (2 wires)	1..5 Vdc (3 wires)	0...10 Vdc (3 wires)	0,5...4,5 ratiometric (3 wires)
Supply voltage, polarity protected	8-32 Vdc	8-32 Vdc	12-32Vdc	5 ± 0,25 Vdc
Supply – current consumption	-	-	4 mA	-
Output impedance	-	-	≤ 90 Ω	-
Load R (connected to 0 V)	See chart	-	R ≥ 5 kΩ	-

PRESSURE RANGES

RANGE (Bar)	4	6	10	16	20	25	40	60	100	160	200	250	400	600	1000
Overpressure (Bar)	8	12	20	32	40	50	80	120	200	320	400	500	800	1200	1200
Burst pressure (Bar)	16	24	40	64	80	100	160	240	400	640	800	1000	1500	1500	1500

MECHANICAL DIMENSIONS

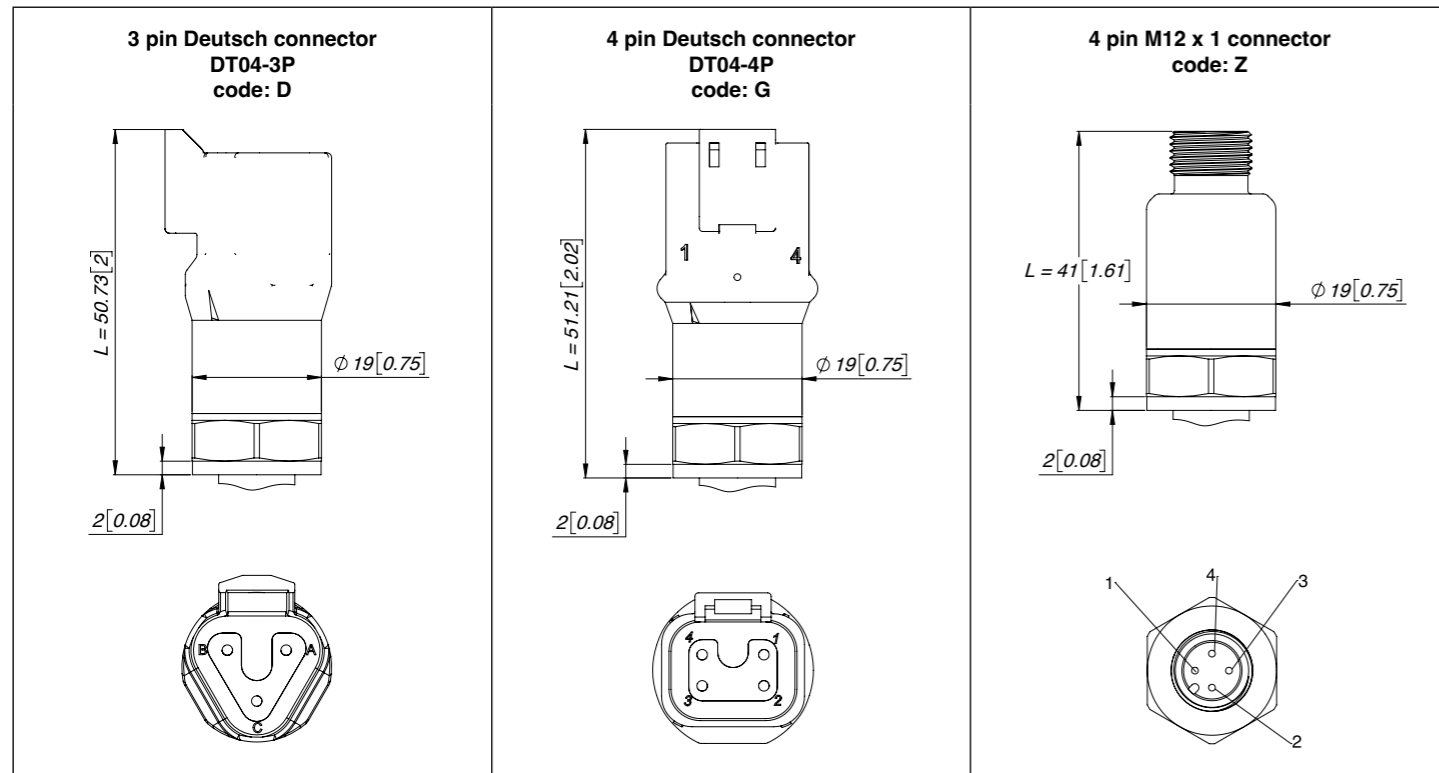
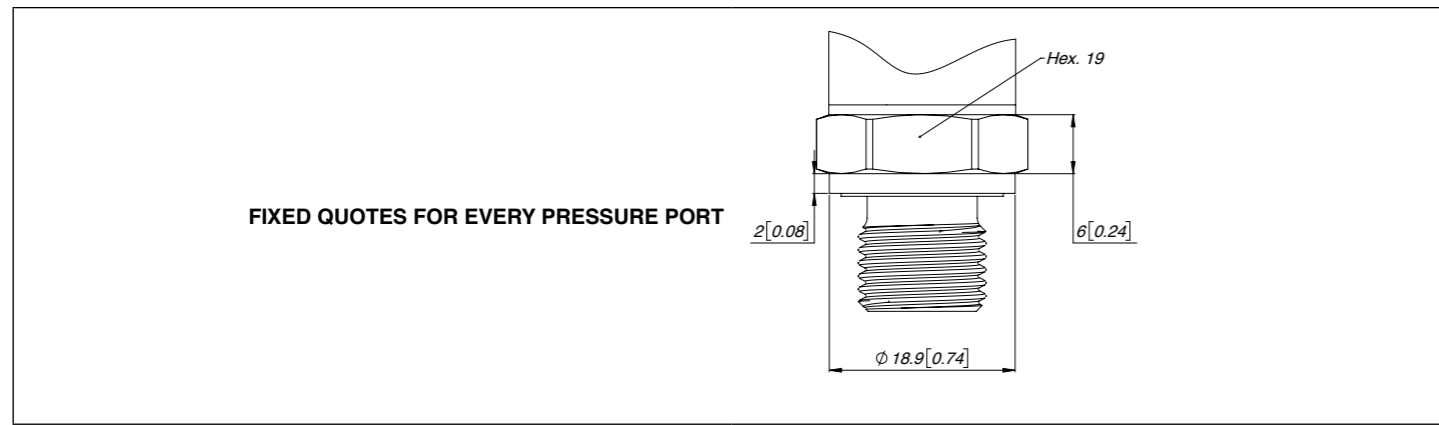

MECHANICAL DIMENSIONS

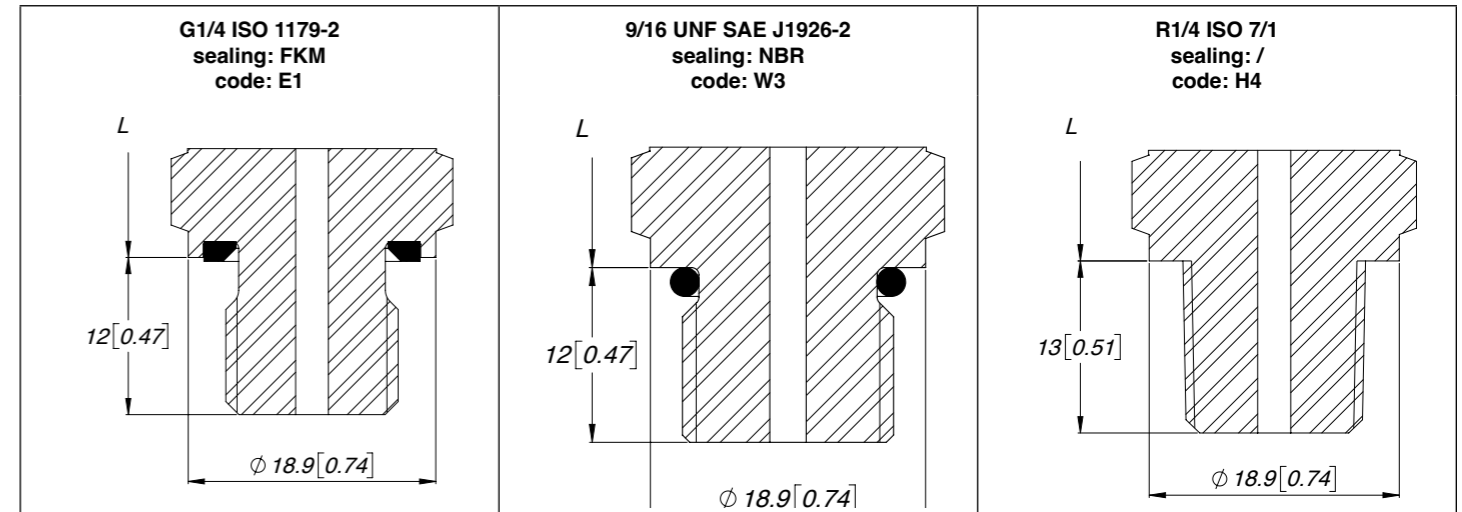

Dimensions in mm. [inches]
Max tightening torque = 30 Nm (Max)

ELECTRICAL CONNECTION - Connectors

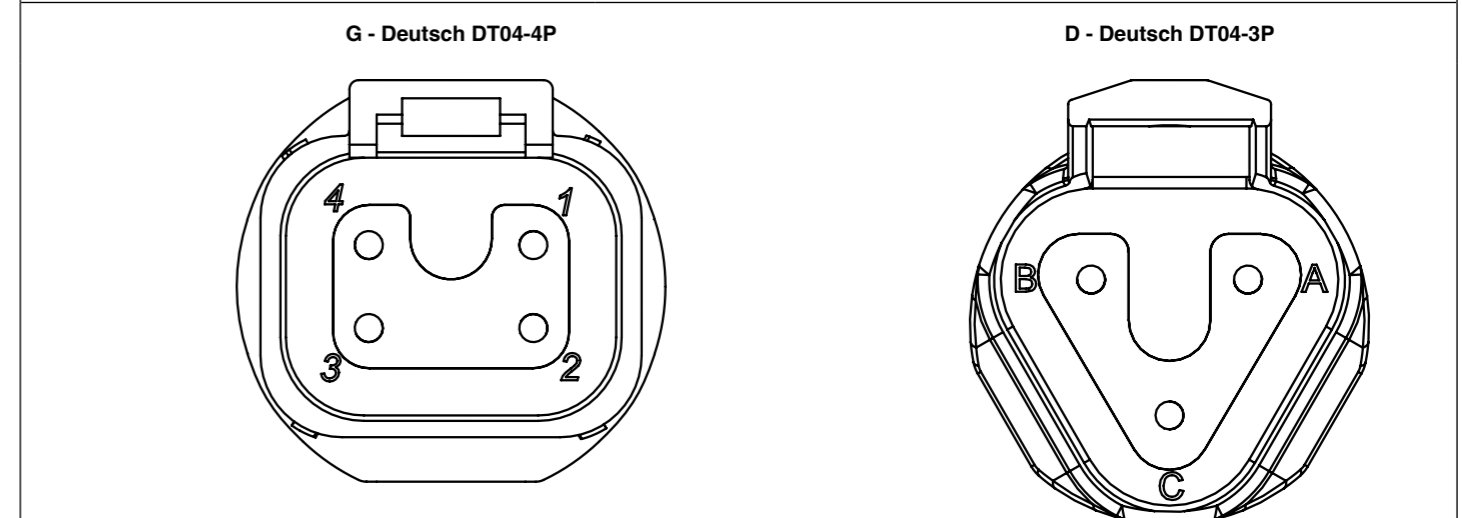
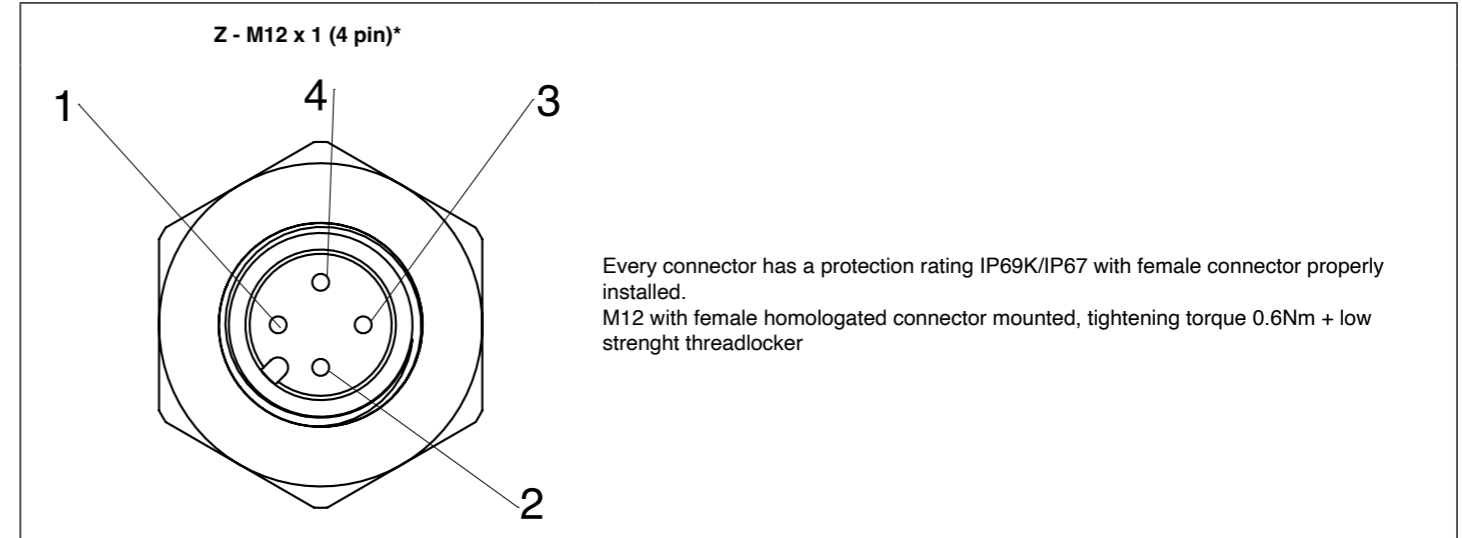

Every connector has a protection rating IP69K/IP67 with female connector properly installed

Notes:

- The IP rating specified in this document normally applies with the suitable female connector plugged-in and properly wired.
- Concerning M12, the pressure transducers with measuring range of 60 bar and below require vented cable and/or mating connector, to allow the compensation of the atmospheric pressure reference.

ELECTRICAL CONNECTION - Connection diagrams

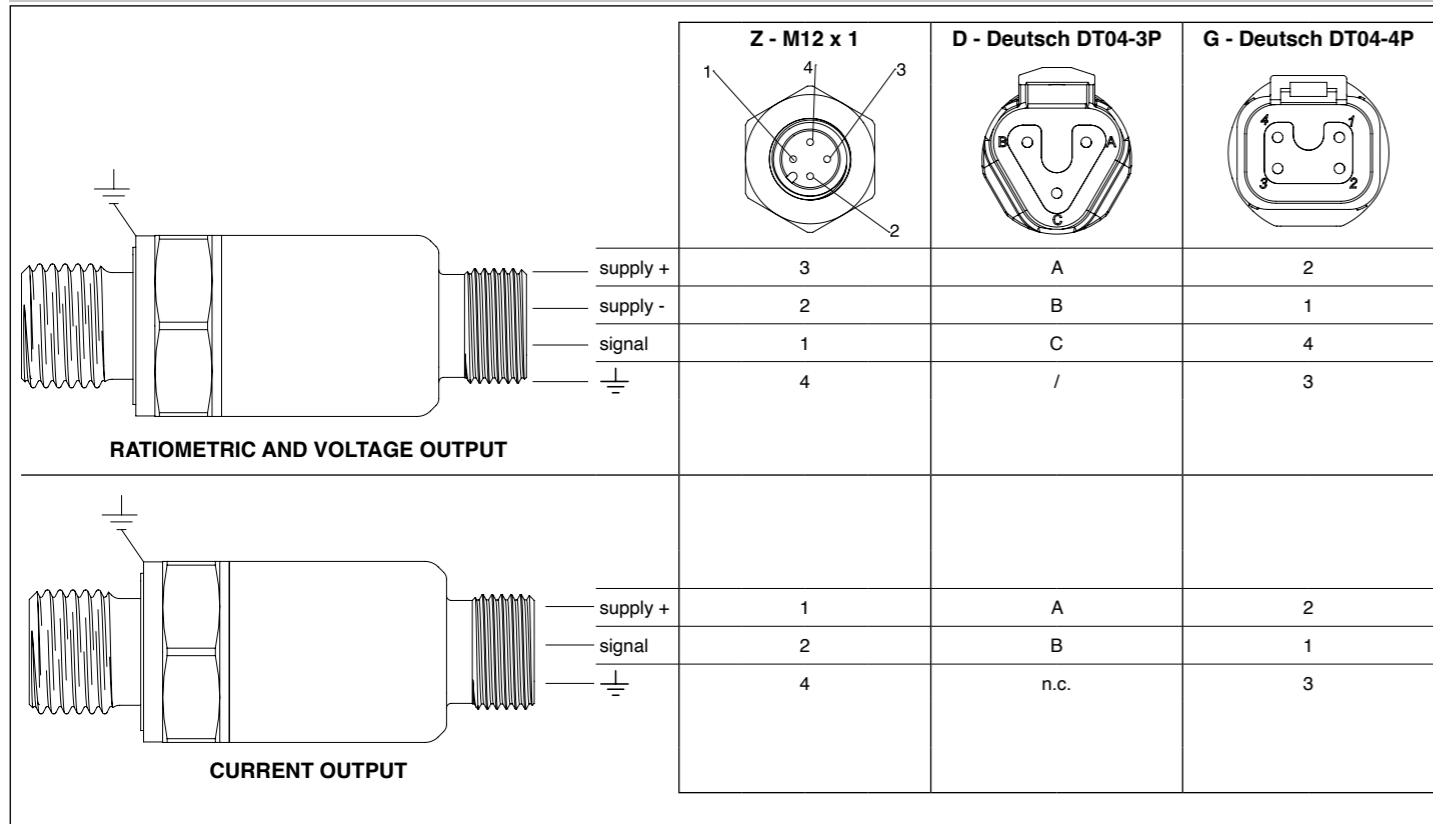

LOAD DIAGRAM

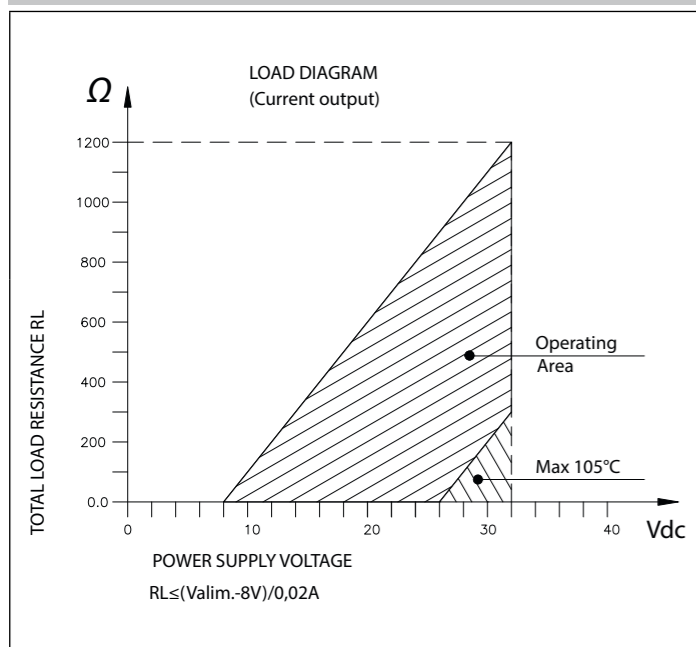

PRESSURE PEAKS PROTECTION

Many industrial applications, especially in hydraulics, could present dangerous phenomena like cavitation, liquid hammer or pressure peaks, due for example to pumps start and stop or fast closing of a valve.

These phenomena can be harmful to the transducer.

The KM series, upon request, is available with an integrated pressure snubber which, thanks to a 0.5 mm diameter through hole, eliminates these harmful peaks, to protect the transducer (see ordering information)



FUNCTIONAL SAFETY (for SIL/PL certified models only)

Safety is a critical requirement especially for machine builders. The European Directive 2006/42/EC defines all the essential requirements in this regard.

In the context of functional safety, the European directive is received by harmonised standards:

- EN IEC 62061 "Safety of machinery - Functional safety of safety-related control systems"
- EN ISO 13849-1 "Safety of machinery - Safety-related parts of control systems - Part 1: General principles for design"

KM pressure transmitters are certified SIL 2 and PL d in accordance with that rule, for use in applications "High Demand Mode" and then may be used in SRECS systems of machinery, where the safety variable to control will be the pressure of a fluid.

NOTES:

- 1) For models with voltage amplified output, SIL2/PL d certification is only available for versions with output at atmospheric pressure greater than zero volts (ie: 1...5V)
- 2) Full specifications, installation and user manual of KM certified SIL2/PL d can be downloaded directly from the website www.gefran.com

EMC compliance according to: Standard / Directive / Regulation	Title
2014/30/EU	EMC Directive (Electromagnetic compatibility)
ISO 13766-1:2018	Earth-moving and building construction machinery — Electromagnetic compatibility (EMC) of machines with internal electrical power supply — Part 1: General EMC requirements under typical electromagnetic environmental conditions
ISO 13766-2:2018 (*)	Earth-moving and building construction machinery — Electromagnetic compatibility (EMC) of machines with internal electrical power supply — Part 2: Additional EMC requirements for functional safety
2015/208/UE	COMMISSION DELEGATED REGULATION (EU) 2015/208 of 8 December 2014 supplementing Regulation (EU) No 167/2013 of the European Parliament and of the Council with regard to vehicle functional safety requirements for the approval of agricultural and forestry vehicles
ECE ONU R10 (Rev 6)	Uniform provisions concerning the approval of vehicles with regard to electromagnetic compatibility

(*) Only applicable to SIL2/PL d certified models

See further details on Declaration of conformity and User Manual

ACCESSORIES ON REQUEST

MATING CONNECTORS

DESCRIPTION	IP RATING	CODE	TEMPERATURE RATINGS **
Connection Z 4 pole female cable connector M12x1	IP67	CON293	-25+85°C
Connection Z 4 pole female cable connector, 90° M12x1	IP67	CON050	-25+85°C

EXTENSION CABLES*

DESCRIPTION	IP RATING	CODE	TEMPERATURE RATINGS **	CABLE COLOR CODE	
				Pin	Wire
Connection Z female connector M12x1 + 2/3/5/10m of cable	* IP67 with female homologated connector mounted, tightening torque 0.6Nm + low strength threadlocker	CAV220	-30+80°C	1	Brown
		CAV221		2	White
		CAV222		3	Blue
		CAV223		4	Black

* Other lengths on request

** The nominal temperature ranges, except where expressly indicated, are also applicable in the UL scope.

For cULus applications extension cables, a 3 pole 26AWG Style 2464 cable is advised

SEALING CODE ACCORDING TO PROCESS CONNECTION

PROCESS CONNECTION	STEEL + NBR	NBR	FKM
G 1/4 ISO 1179-2			GUA036
9/16 UNF SAE J1926-2		GUA208	
R 1/4 ISO 7/1			

ACCESSORIES DRAWINGS

DESCRIPTION	CODE	DRAWING
Connection Z 4 pole female cable connector M12x1	CON293	
Connection Z 4 pole female cable connector, 90° M12x1	CON050	
Connection Z female connector M12x1 + 2/3/5/10m of cable	CAV220 CAV221 CAV222 CAV223	

ORDERING INFORMATION

K M - N E1 Z - B04C - S - 0 - 00 - 00 - X X X X X 0 0 0 - B50 - 0 0 0

OUTPUT SIGNAL	
0,5...4,5 V ratiometric	X
0...10 V	N*
1...5 V	P
4...20 mA	E

*SIL /PL Certification not available

PROCESS CONNECTIONS	
G 1/4 ISO 1179-2	E1
9/16 UNF SAE J1926-2	W3
R 1/4 ISO 7/1	H4

ELECTRICAL CONNECTIONS	
M12x1 (4-pin)	Z
Deutsch DT04-4P (4-pin)	G
Deutsch DT04-3P (3-pin)	D

MEASUREMENT RANGE			
bar		bar	
B04U	4	B01C	100
B06U	6	B16D	160
B01D	10	B02C	200
B16U	16	B25D	250
B02D	20	B04C	400
B25U	25	B06C	600
B04D	40	B01M	1000
B06D	60		

Available on request other measurement range and measurements unit

CALIBRATION STANDARDS

Instruments manufactured by Gefran are calibrated against precision pressure calibration equipment which is traceable to International Standards.

Example

KM-NE1Z-B04C-S-0-00-00-XXXXX000-B50-000

KM pressure transmitter with 0...10V output signal, G1/4 male with snubber (ISO 1179-2) pressure connection, M12 electrical connector, 0...400 bar pressure range, Pin Out (OUT, V-, V+, GND), No SIL2/PL d, box 50 pcs.

Sensors are manufactured in compliance with: - EMC 2014/30/EU Compatibility Directive
 - RoHS 2011/65/EU Directive
 - 2006/42/EC Machinery Directive

Electrical installation requirements and Conformity certificate are available on our web site: www.gefran.com

Mechanical and/or electrical characteristics differing from standard may be arranged on request.

PACKAGING	
Batch of 50pcs in single box	B50

CERTIFICATIONS	
NO SIL2/PL d	0
SIL2/PL d*	1

*SIL/PL certification not available with N output signal

SNUBBER	
Without snubber	0
With snubber	s

GEFRAN spa reserves the right to make any kind of design or functional modification at any moment without prior notice.